

Sigma control

Heating cables

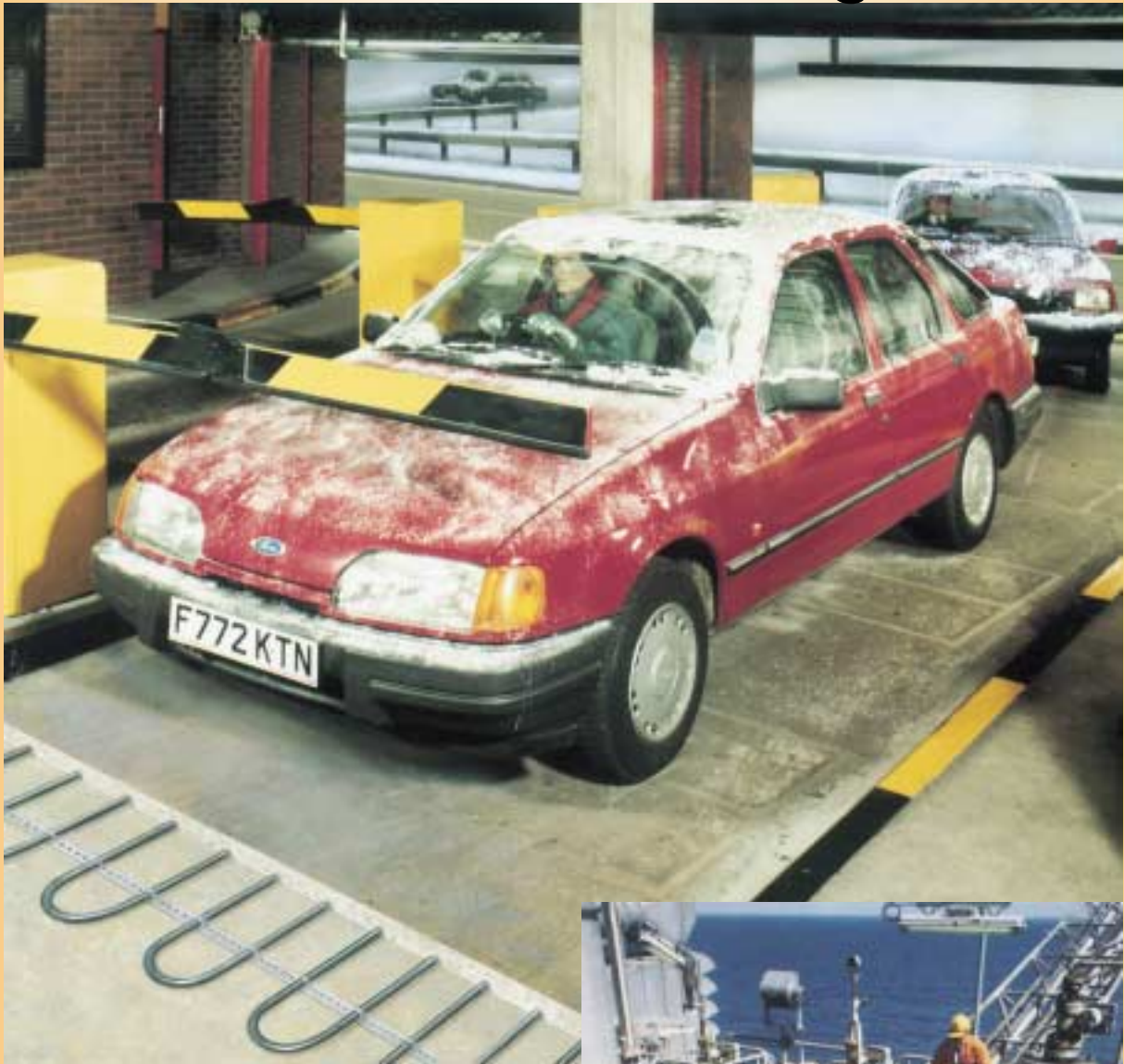

Design guide

Sigma control

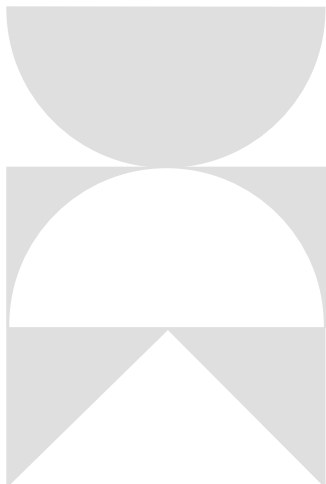

A Pipe temperature maintenance

For frost protection or pipe temperature maintenance, the heater power output is equivalent to heat loss across the insulation. To calculate this, it is necessary to use the below indicated formula:

$$PM = \frac{3,2 \cdot K \cdot (T-t)}{E \cdot \text{Log} \left(\frac{D+2S}{D} \right)}$$

Where:

PM	heater power output (W/m)
K	insulating thermal conductivity (W/m °C)
T	temperature to be maintained (°C)
t	minimum ambient temperature (°C)
D	pipe OD size (mm)
E	efficiency factor, normally 0.73
S	insulation thickness (mm)

B Pipe raising temperature

To warm up a pipe, use the below indicated formula:

$$PR = \frac{(P \cdot S + C \cdot Q) \cdot T}{H \cdot E \cdot 0,864}$$

Where:

PR	heater power output (W/m)
P	pipe weight (Kg/m)
S	specific heat of pipe (J/Kg °C)
C	weight of contents (Kg/m)
Q	specific heat of contents (J/Kg °C)
T	temperature raise (°C)
H	time allowed (h)
E	efficiency factor, normally 0.73

The total value of heating required must take care also of the heat loss compensation and consequently this value will be:

$$P_{TOT} = PR + \frac{2}{3} PM$$

Design guide

Sigma control

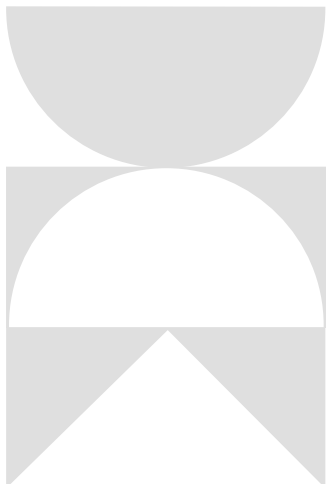

C Tanks temperature maintenance

For frost protection or tank temperature maintenance, the heater power output is equivalent to heat loss across the insulation. To calculate this, it is necessary to use the below indicated formula:

$$PM = \frac{A \cdot K \cdot (T_1 - T_2)}{t \cdot E \cdot 0,864}$$

Where:	PM	heater power output (KW)
	A	total surface area of tank (m ²)
	K	insulating thermal conductivity (W/m °C)
	T₁	temperature to be maintained (°C)
	T₂	minimum ambient temperature(°C)
	t	isolation thickness (mm)
	E	efficiency factor, normally 0.73

D Tanks raising temperature

To warm up a tank, use the below indicated formula:

$$PR = \frac{(P \cdot S + C \cdot Q) \cdot T}{H \cdot E \cdot 0,864}$$

Where:	PR	heater power output (W/m)
	P	tank weight (Kg/m)
	S	specific heat of tank (J/Kg °C)
	C	weight of contents of tank (Kg/m)
	Q	specific heat of contents (J/Kg °C)
	T	temperature raise (°C)
	H	time allowed (h)
	E	efficiency factor, normally 0.73

The total value of heating required must take care also of the heat loss compensation and consequently this value will be:

$$P_{TOT} = PR + \frac{2}{3} PM$$



Design guide

Ice, frost and snow protection for ramps

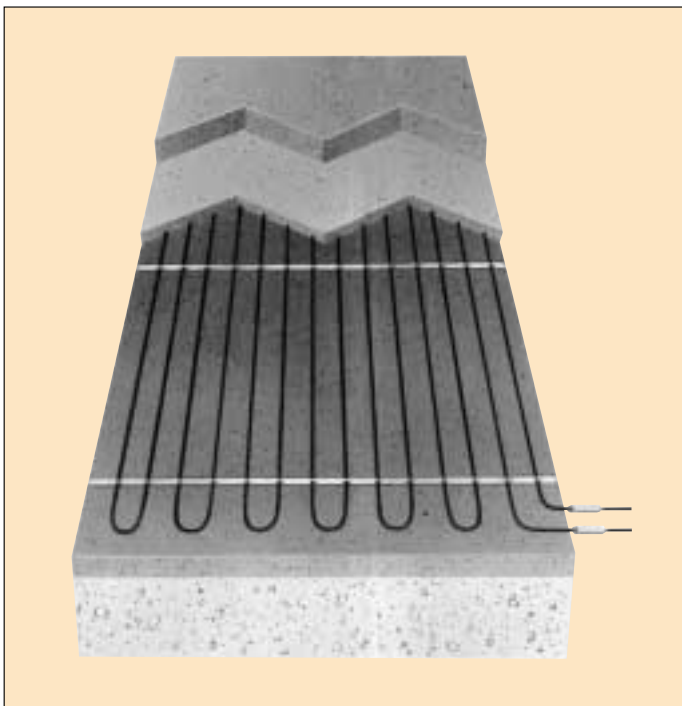

E Ice, frost and snow protection for ramps

Notwithstanding the heat transmission of road surface depends on several factors, the wide experience in Scandinavian countries and the always more and more generalized standardizations have consented to the British Institute of road engineering to determine the values of specific power necessary to prevent the formation of ice and snow accumulation .

$P = 125 \text{ W/m}^2$	for mild climates
$P = 150 \text{ W/m}^2$	for cold climates
$P = 200 \text{ W/m}^2$	for northern climates

This application can be done with mineral insulated or self-regulating cables. We are at your service to find the most suitable technical and economical solution.

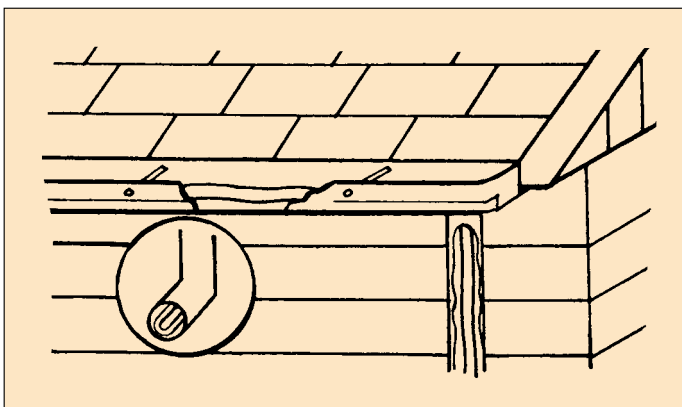

F Roof and gutter frost protection

For frost protection of roofs till 100mm width, the necessary power is 30-40W/mt. To prevent accumulation of ice and snow on roofs, the heat power necessary is 350W/mt2.

NOTE: Our technical department is at Your service to find the proper solution of every application.

Self-limiting heating cables

the easiest solution for frost protection

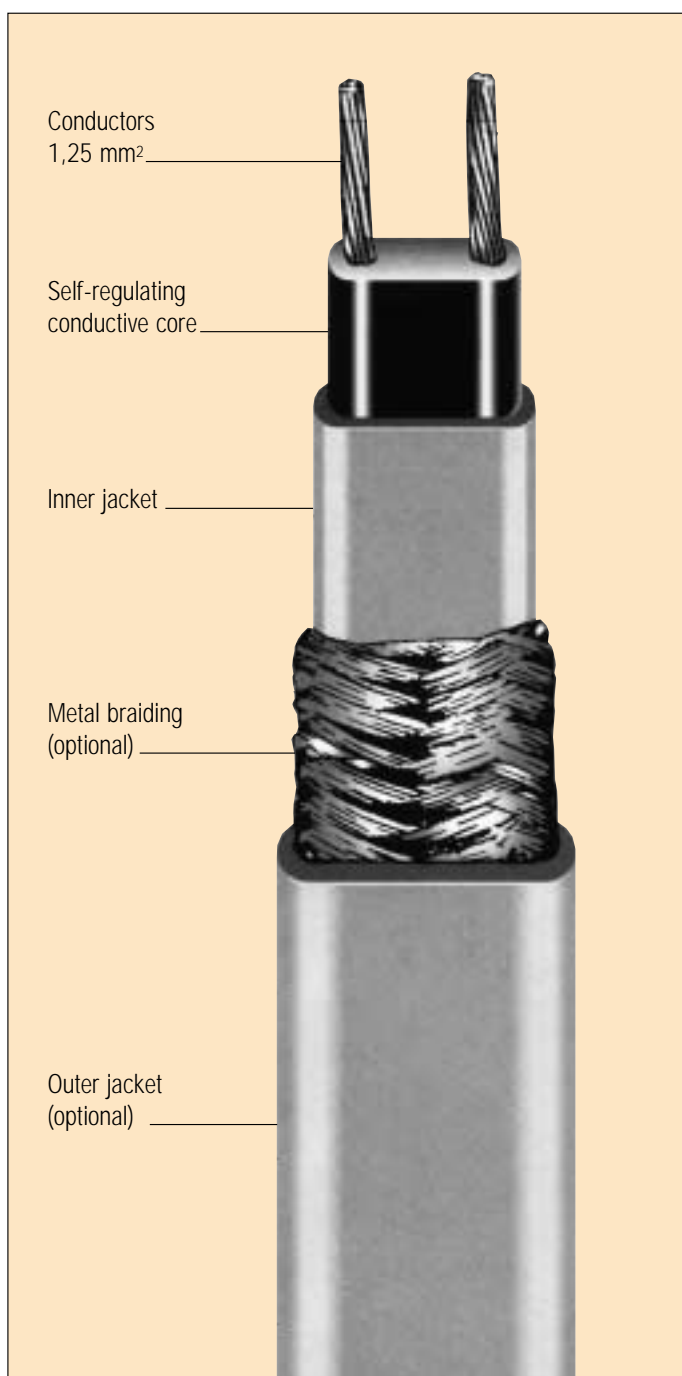

The self-regulating heating cables increase or reduce the heat output in response to changes in temperature, irrespective of the heating circuit length. Consequently the main features of this cable are:

- **energy consumption related at the real thermal conditions**
- **reduced design activities**
- **possibility to make junctions or to cut off in needed length at site without change of heat power per meter**
- **No overheat in case of touch or overlap each other**

The simple construction of these cables (similar to electric power cables) makes easy the activity of installation and connection, reducing the mounting costs.

APPLICATIONS

- **frost protection**
- **heating and maintenance in tanks and pipes (max temperature maintenance 120°C)**
- **prevention of ice formation and snow accumulation**
- **recycling**



Self-limiting heating cables series CT

“commercial” series



Power At 10°C/230V 10 W/m	Length Max circuit 100 m	Code CT10
--	---------------------------------------	-------------------------

TYPES

Code	Braiding	Sizes
063	Tin plated copper braid and TPE overjacket	7,5 x 5,3 mm
064	Tin plated copper braid and fluoropolymer protective jacket	7,5 x 5,3 mm

APPLICATIONS

- pipes frost protection
- tanks frost protection
- sprinkler frost protection
- floor warming

TECHNICAL DATAS

Power supply: 220/240V (120V on request)

Conductors CSA: 0.56mm²

Minimum bending radius: 35mm

Minimum installation temperature: -30°C

Maximum operating temperature (1000h cumulated): 65°C cable powered
85°C cable not powered

Braid max resistance: 18.2 Ω/km

Approvals: SEMKO 9806158/01-02

NOTE : our self-regulating heating cables series “CT” are “CE” marked.



Self-limiting heating cables series CT

"commercial" series



ORDERING CODES

35 — XXX — XX — CT

code **power**

063
064

10

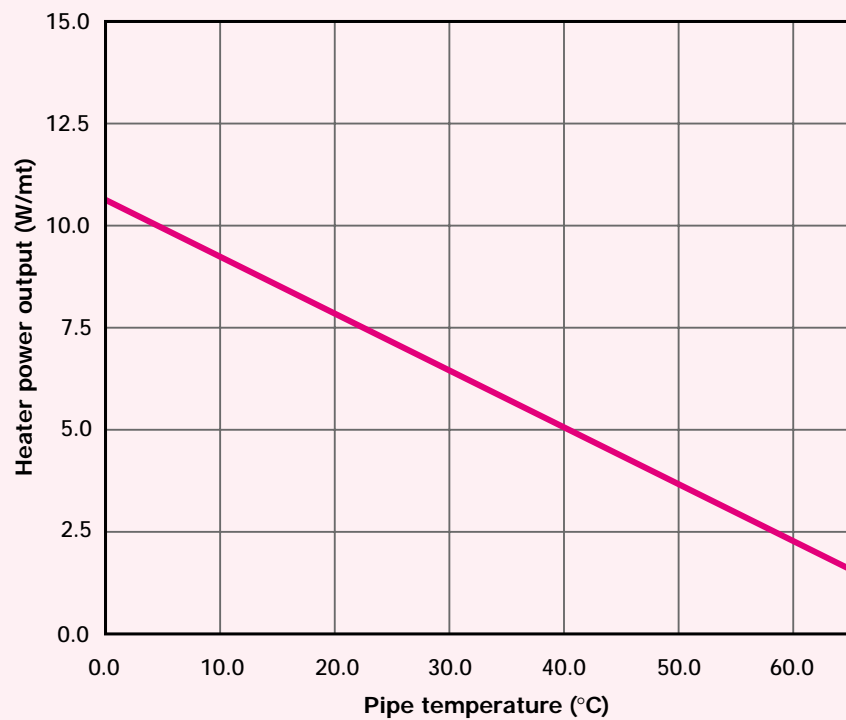



Self-limiting heating cables series **ST**

“civil” series



Power At 10°C/230V	Max circuit length	Code
10 W/m	132 m	ST10
15 W/m	93 m	ST15
20 W/m	71 m	ST20
25 W/m	57 m	ST25

TYPES

Code	Braiding	Sizes
073	Tin plated copper braid and TPE overjacket	10,5 x 6 mm
074	Tin plated copper braid and fluoropolymer protective jacket	10,5 x 6 mm

APPLICATIONS

- *pipes frost protection*
- *tanks frost protection*
- *sprinkler frost protection*
- *floor warming*

TECHNICAL DATAS

Power supply: 220/240V (120V on request)

Conductors CSA: 1.00mm²

Minimum bending radius: 25mm

Minimum installation temperature: -30°C

Maximum operating temperature (1000h cumulated): 65°C cable powered
85°C cable not powered

Braid max resistance: 18.2 Ω/km

Approvals: SEMKO 9806158/01-02

NOTE : our self-regulating heating cables series “ST” are “CE” marked.



Self-limiting heating cables series ST

"civil"
series



ORDERING CODES

35 — XXX — XX — ST

code power

073

10

074

18

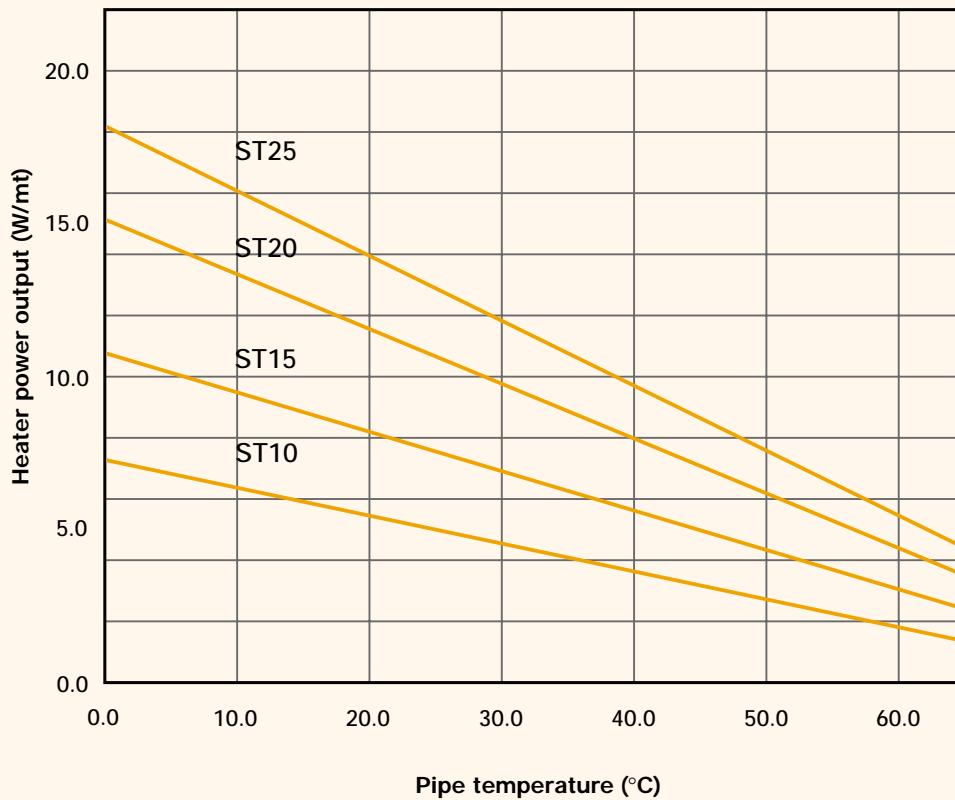



Self-limiting heating cables

series FT



"industrial" series



Power At 10°C/230V	Max circuit length	Code	Temperature class
10 W/m	205 m	FT10	T6
15 W/m	145 m	FT15	T6
20 W/m	110 m	FT20	T6
25 W/m	88 m	FT25	T6
33 W/m	70 m	FT33	T5

TYPES

Code	Braiding	Sizes
011	None	10,0 x 4,0 mm
012	Tin plated copper braid	10,5 x 4,5 mm
013	Tin plated copper braid and TPE overjacket	11,5 x 5,5 mm
014	Tin plated copper braid and fluoropolymer protective jacket	11,5 x 5,5 mm

TECHNICAL DATAS

Power supply: 220/240V (120V on request)
 Conductors CSA: 1.25mm²
 Minimum bending radius: 25mm
 Minimum installation temperature: -30°C
 Maximum operating temperature (1000h cumulated): 80°C cable powered
 100°C cable not powered

Braid max resistance: 18.2 Ω/km
 Approvals: KEMA certificate nr. EX-00.E.2028U
 DIN VDE 0254 licence nr. 107584

APPLICATIONS

- pipes frost protection
- tanks frost protection
- sprinler frost protection
- pipes heating
- tanks heating
- recycling
- prevention of ice formation and snow accumulation on ramps, roofs and guttersgronde

NOTE : our self-regulating heating cables series "FT" are "CE" marked



Self-limiting heating cables series FT



"industrial" series

ORDERING CODES

35 — XXX — XX — FT

code power

011	10
012	15
013	20
014	25
	33

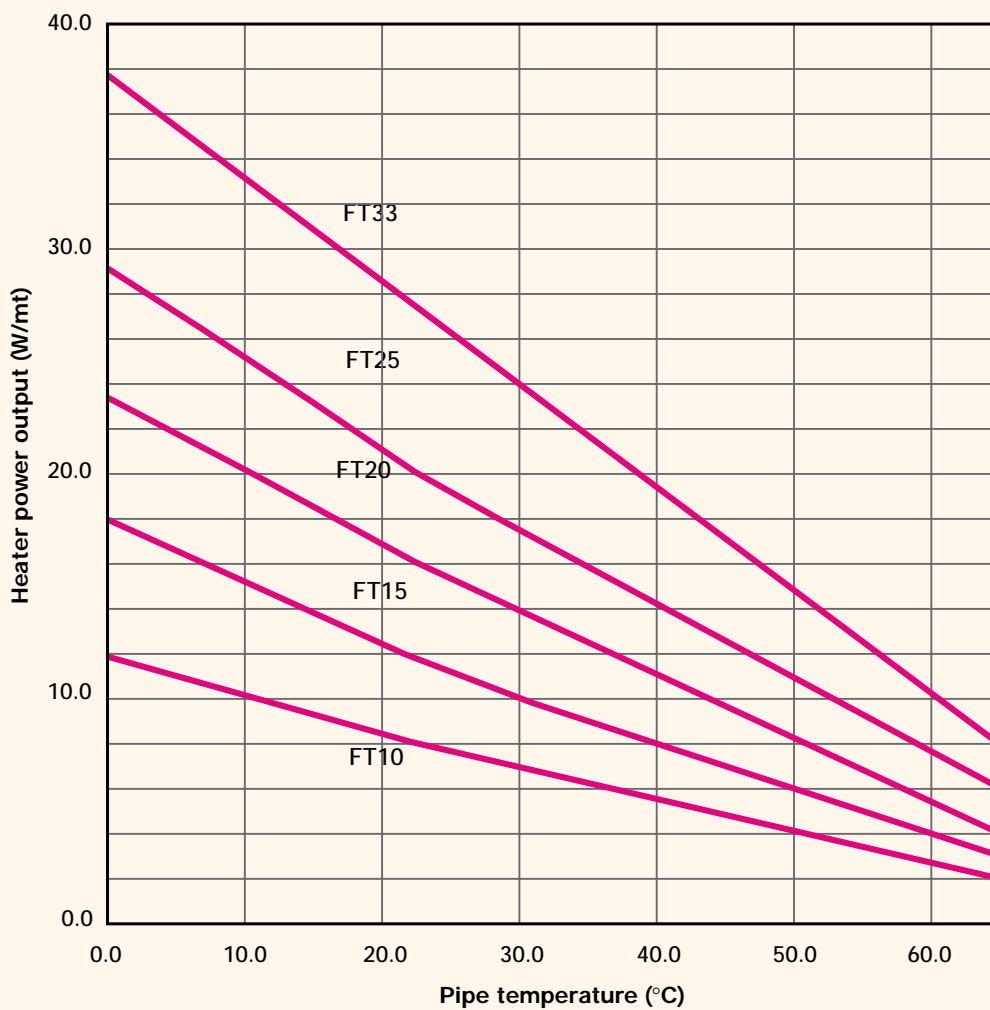

Self-limiting heating cables series PT



"industrial" series



Power At 10°C/230V	Max circuit length	Code	Temperature class
10 W/m	200 m	PT10	T3
15 W/m	165 m	PT15	T3
20 W/m	135 m	PT20	T3
25 W/m	120 m	PT25	T3
30 W/m	85 m	PT30	T3
45 W/m	70 m	PT45	T3
60 W/m	50 m	PT60	T3

TYPES

Code	Braiding	Sizes
041	None	8,5 x 3,5 mm
042	Tin plated copper braid	9,5 x 4,0 mm
043	Tin plated copper braid and TPE overjacket	10,5 x 5,0 mm
048	Tin plated copper braid and fluoropolymer protective jacket	10,5 x 5,0 mm

TECHNICAL DATAS

Power supply: 220/240V (120V on request)
 Conductors CSA: 1.25mm²
 Minimum bending radius: 25mm
 Minimum installation temperature: -30°C
 Maximum operating temperature (1000h cumulated): 120°C cable powered
 200°C cable not powered
 (120°C for type 044)

Braid max resistance: 18.2 Ω/km
 Approvals: KEMA certificate nr. EX-00.E.2029U
 DIN VDE 0254 licence nr. 107586
 KEMA 02 ATEX2285U
 EN 50014:1997
 EN 50019:2000

APPLICATIONS

- pipes frost protection
- tanks frost protection
- pipes heating
- tanks heating
- hoppers heating
- prevention of ice formation and snow accumulation on ramps
- systems heating

NOTE : our self-regulating heating cables series "PT" are "CE" marked.



Self-limiting heating cables series PT



"industrial" series



ORDERING CODES

35 — XXX — XX — PT

code power

code	power
041	10
042	15
044	20
048	25
	30
	45
	60

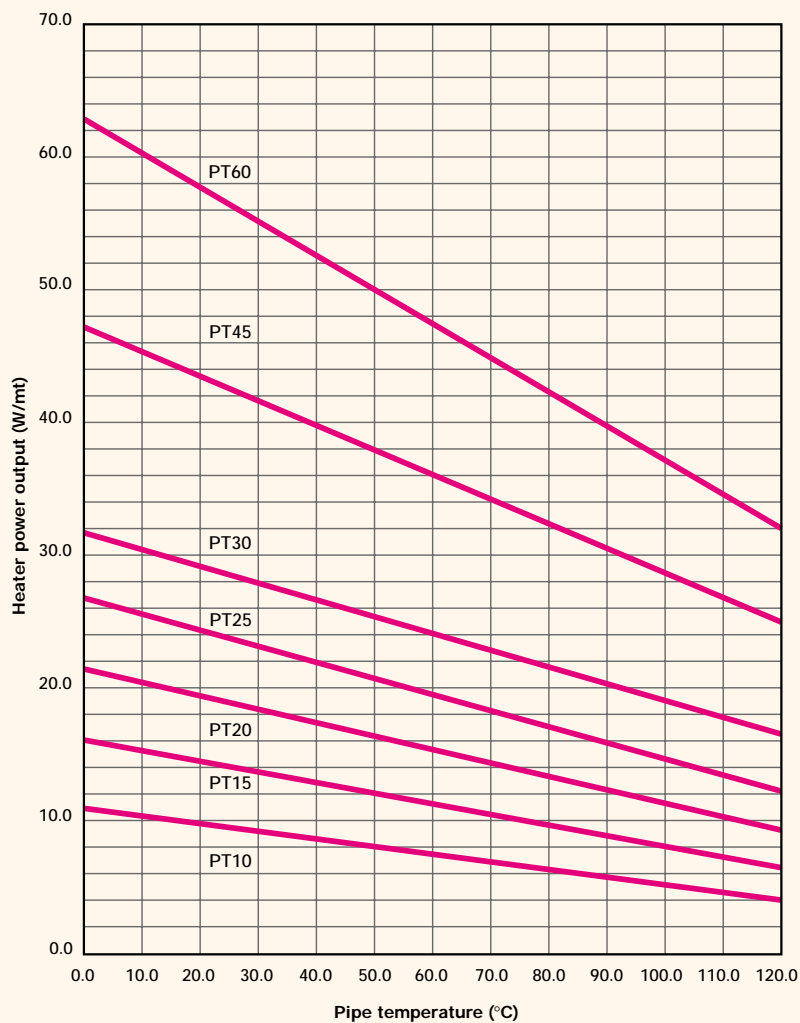



Accessories

products for self-limiting heating cables

CONNECTION KIT FOR SAFE AREAS

KA-CT	Input power termination kit for cables series "CT"
KA-ST	Input power termination kit for cables series "ST"
KA-FT/PT	Input power termination kit for cables series "FT-TM-PT"
KC-CT	Insulation crossing kit for cables series "CT"
KC-ST/FT/PT	Insulation crossing kit for cables series "ST-FT-TM-PT"
KG-CT	Splice connection kit for cables series "CT"
KG-ST/FT/PT	Splice connection kit for cables series "ST-FT-TM-PT"
KF-CT	End termination kit for cables series "CT"
KF-ST/FT/PT	End termination kit for cables series "ST-FT-TM-PT"

CONNECTION KIT FOR HAZARDOUS AREAS

KA-EX1	Input power termination kit for cables series "FT-TM-PT"
KF-EX1	End termination kit for cables series "FT-TM" type "013"
KF-EX2	End termination kit for cables series "FT-TM" type "014"
KF-EX3	End termination kit for cables series "PT" type "043"

JUNCTION BOXES

CS-1	Water proof plastic junction box 139x119 - 1 / 2 input
CS-2	Metallic water proof junction box 125x125 - 1 input
CS-3	Metallic water proof junction box 125x125 - 2 input
CS-4	Metallic EEx-e junction box 140x140 - 1 input
CS-5	Metallic EEx-e junction box 140x140 - 2 input
CS-6	Metallic EEx-d junction box (diameter) 89 - 1 input
CS-7	Metallic EEx-d junction box 120x120 - 2 input

THERMOSTATS

TS-1	Ambient thermostat for safe areas Set points: 4-14°C
TS-2	Hazardous areas ambient thermostat Set points: 4-14°C
TS-3	Line bulb thermostat L=2mt for safe areas Scale -10 : 90°C
TS-4	Line bulb thermostat L=2mt for safe areas Scale 0 : 150°C
TS-5	Line bulb thermostat L=2mt for safe areas Scale 20 : 320°C
TS-6	Line bulb thermostat in metallic enclosure L=2mt for safe areas Scale -10 : 90°C



Accessories

products for self-limiting heating cables

JUNCTION BOX MOUNTING BRACKET

- TS-7** Line bulb thermostat in metallic enclosure
L=2mt for safe areas
Scale 0 : 150°C
- TS-8** Line bulb thermostat in metallic enclosure
L=2mt for safe areas
Scale 20 : 320°C
- TS-9** Ex-d line bulb thermostat L=2mt
Scale -10 : 90°C
- TS-10** Ex-d line bulb thermostat L=2mt
Scale 0 : 150°C
- TS-11** Ex-d line bulb thermostat L=2mt
Scale 20 : 320°C

- ST-1** Mounting bracket for junction box type "CS-1"
- ST-2** Mounting bracket for junction box type "CS-2", "CS-3"
- ST-3** Mounting bracket for junction box type "CS-4", "CS-5"
- ST-4** Mounting bracket for junction box type "CS-6"
- ST-5** Mounting bracket for junction box type "CS-7"
- ST-6** Mounting bracket for thermostat type "TS-6", "TS-7", "TS-8"
- ST-7** Mounting bracket for thermostat type "TS-9", "TS-10", "TS-11"

ADHESIVE TAPES FOR FIXING/COVERING

- NS-1** Fiber-glass reinforced polypropylene adhesive tape 19x50mt.
Max operating temperature 60°C
- NS-2** Polyester reinforced aluminium adhesive tape 19x50mt.
Max operating temperature 90°C
- NS-3** Aluminium 40 micron thickness adhesive tape 19x50mt.
Max operating temperature 120°C
- NS-4** Silicon polyester adhesive tape 19x66mt.
Max operating temperature 150°C
- NS-5** Katton adhesive tape 19x33mt.
Max operating temperature 200°C
- NS-6** Aluminium foil 40 micron thickness 50x50mt.
Max operating temperature 120°C
- NS-7** Aluminium foil 130 micron thickness 50x55mt.
Max operating temperature 150°C

OTHERS

- TG-1** Adhesive caution label in Italian and English.



PTFE series heating cables



Approvazioni

- LCIE 01 ATEX 6048 X
Direttive 94/9/EC
- EN 50014 (1997)
- EN 50018 (1994)
- EN 50019 (2000)

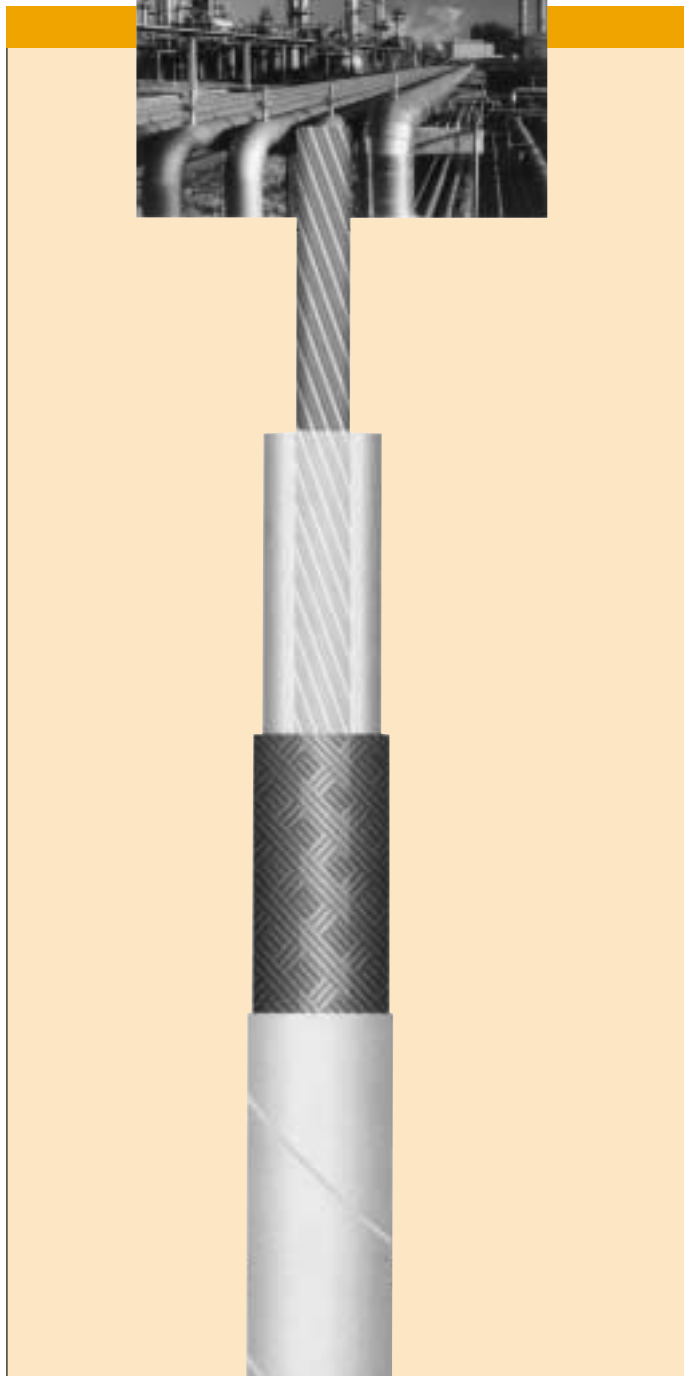

Cable description

- High chemical resistance
- For every application
- High resistance
- High operating temperature
- Can be used into liquid

Technical datas of PTFE series heating

Insulation	PTFE
Grounding braid	Tin plated copper
Cable sheat	PTFE
Max operating temperature	220 °C
Operating voltage	500 V
*Max operating power	30 W/m
Max bending	20 mm
Max installation temperature	-50 °C

*NOTE: A lower power allows an higher working temperature. Higher power is possible with higher heat transfer. For possible operating conditions upper temperature limits, contact us.

Cable construction

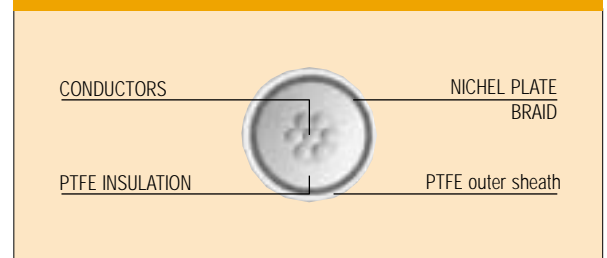

PTFE heating cables

for temperature up to 250°C

type ELKM-AG



EEx e II T3, T4 o T5
EEx ed IIC T3, T4 o T5

Tecnical data

Resistance (Ω/mt)	Cable Diameter (mm)	Conductor Material	Temperature Coefficient	Cable Code	Correction Factor (mm)
0,0117	5,1	Stranded	1,43	0138010	0,647
0,0263	4,7	Stranded	1,43	0138018	0,702
0,034	4,6	Stranded	1,43	0138022	0,717
0,05	4,9	Stranded	1,3	0138030	0,673
0,08	4,6	Stranded	1,3	0138038	0,717
0,01	5,1	Stranded	1,04	0138042	0,647
0,14	4,9	Stranded	1,04	0138046	0,673
0,16	4,8	Stranded	1,04	0138050	0,687
0,2	4,8	Stranded	1,04	0138054	0,687
0,26	4,6	Stranded	1,04	0138058	0,717
0,34	4,4	Stranded	1,04	0138062	0,750
0,43	4,6	Stranded	1,018	0138066	0,717
0,51	4,5	Stranded	1,018	0138070	0,733
0,53	4,5	Stranded	1,018	0138074	0,733
0,68	4,4	Stranded	1,018	0138078	0,750
1,0	4,5	Stranded	1	0138082	0,733
1,25	4,4	Stranded	1	0138086	0,750
1,44	4,3	Stranded	1	0138090	0,767
1,75	4,3	Stranded	1	0138094	0,767
2,06	4,5	Stranded	1,029	0138098	0,733
2,5	4,4	Stranded	1,029	0138102	0,750
3,1	4,8	Spirally wound	1,04	0138106	0,687
3,4	4,8	Spirally wound	1,04	0138110	0,687
4,0	4,8	Spirally wound	1,018	0138114	0,687
4,7	4,8	Spirally wound	1,018	0138118	0,687
5,7	4,8	Spirally wound	1,018	0138122	0,687
7	4,8	Spirally wound	1,018	0138126	0,687
9	4,8	Spirally wound	1,018	0138130	0,687
11	4,8	Spirally wound	1,018	0138134	0,687
13	4,8	Spirally wound	1	0138138	0,687
15	4,8	Spirally wound	1	0138142	0,687
20	4,8	Spirally wound	1	0138146	0,687
25	4,8	Spirally wound	1	0138150	0,687
30	4,8	Spirally wound	1	0138154	0,687
40	4,8	Spirally wound	1	0138158	0,687
50	4,8	Spirally wound	1	0138162	0,687
60	4,8	Spirally wound	1	0138166	0,687
80	4,8	Spirally wound	1	0138170	0,687
100	4,8	Spirally wound	1,006	0138174	0,687
117	4,8	Spirally wound	1,029	0138178	0,687
160	4,8	Spirally wound	1,029	0138182	0,687
200	4,8	Spirally wound	1,006	0138186	0,687
300	4,8	Spirally wound	1,006	0138190	0,687
450	4,8	Spirally wound	1,006	0138194	0,687
600	4,8	Spirally wound	1,006	0138198	0,687
1500	4,8	Spirally wound	1,002	0138202	0,687

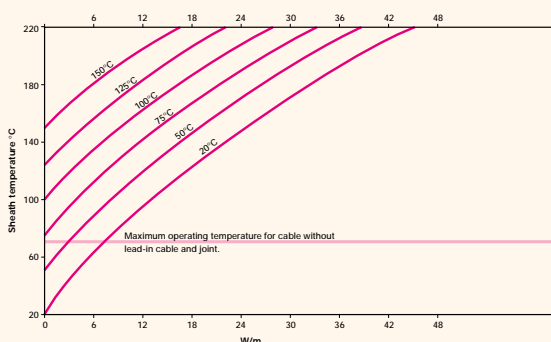

Sheath temperature

Max operating temperature for cable HDP oversheathed To calculate Maximum Operating Temperature, obtain watts per metre of cable, refer to ratings table, and multiply watts per metre by the radio. Enter graph at "new" watts/metre, and read off sheath temperature at point of intersection of relevant maintain temperature.

ELKM - AS 0,0017 ohm/m 1,5mm² cold lead

ELKM - AS 0,0072 ohm/m 2,5mm² cold lead

Accessories

- ELVB-30 = Connection kit for cold lead 1,5 mm²
- EX CON = Connection kit for cold lead 1,5/2,5 mm²
- II GD-EEx II T3 bis T6
- Certificate n° IBEX U04 ATEX 1005X

Mineral insulated Heating cables

when frost protection is vital

Mineral insulated cables are widely used to solve easily and economically problems of heating or temperature holding.

Benefits offered by heat tracing with mineral insulated cables are:

- **uniform distribution of heat**
- **easy to be installed**
- **no maintenance costs**

APPLICATIONS

- **chemical industry**

For heat up and temperature maintenance of tanks and vessels. To keep products at required temperatures during process.

- **refineries**

Heating and temperature holding of pipes, valves, pumps, filters and tanks.

- **thermoelectric power plants**

Heating and temperature holding in pumping stations, pipes, valves, oil tanks.

Frost protection of water pipe lines.

Heating and temperature maintenance of soda lines.

Heating and temperature holding of hoppers.

Heating of bunker oil tanks.

- **food industry**

Heating of pipe lines containing chocolate, molasses, etc. to be maintained fluid.

Heating of tanks containing glucose and sugar.

- **gas industry**

Frost protection of distribution pipelines.

Heating of pipes and valves to prevent the condensation of gas.

- **pharmaceutical industry**

Heating of pipelines and vessels containing creams, oils and ointments.

- **building**

Roofs, gutters and ramps heating.

Frost protection of access ramps to car parks.

Frost protection of access ramps to road of bridges and tunnels.



Mineral insulated Heating cables series "MIC"

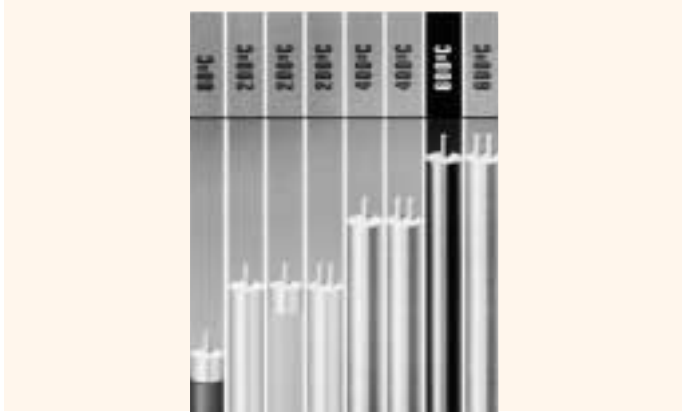
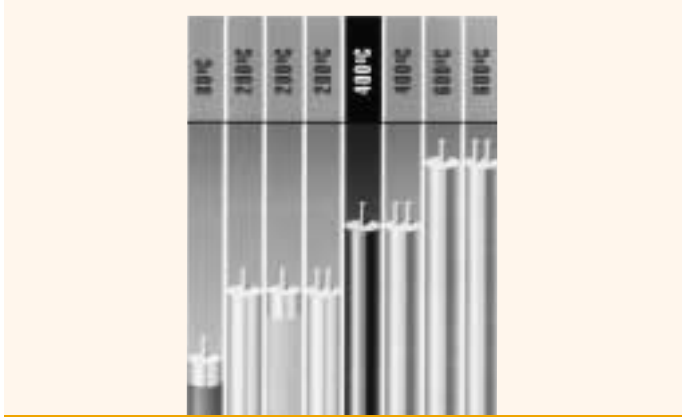
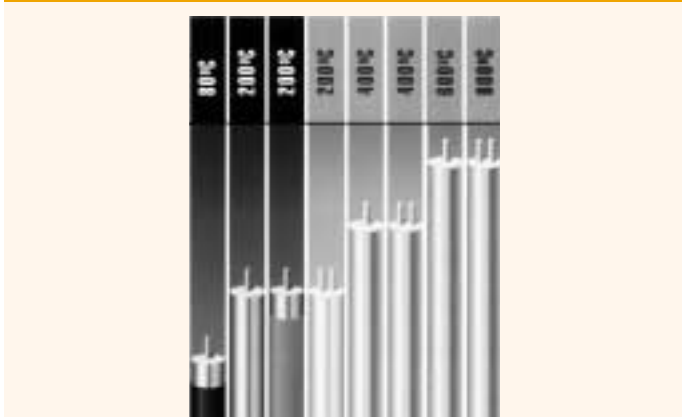

A *Copper sheathed MIC heating cable*

Sheath material	rame
Insulation	MgO
Voltage test	2,0 KV rms ac
Insulation resistance	1000 MΩ/1000 m
Max operating temperature	200 Deg °C
Approvals	BASEEFA DIN GOST

Note: Possibility of corrosion resistant over-sheath
 - HDPE Max operating temperature 80°C
 - FEP 140 Max operating temperature 200°C
 - PTFE Max operating temperature 200°C

B *Cupro-nickel MI heating cable*

Sheath material	70/30 cupro-nickel
Insulation	MgO
Voltage test	2,0 KV rms ac
Insulation resistance	1000 MΩ/1000 m
Max operating temperature	400 Deg °C
Approvals	BASEEFA DIN GOST

C *Stainless steel MI heating cable*

Sheath material	acciaio inox 321
Insulation	MgO
Voltage test	2,0 KV rms ac
Insulation resistance	1000 MΩ/1000 m
Max operating temperature	600 Deg °C
Approvals	BASEEFA DIN GOST

NOTE: On request can be supplied MIC cable Inconel sheathed



MIC Copper sheathed heating cables

Technical data

Code	Cable diameter (mm)	Conductor Material	Conductor Diameter (mm)	Resistance (Ω/Km)	Coil Length (m)	Spool Diameter (m)	Weight (Kg/Km)
CH2000	2,8	Copper Alloy	0,51	2000	1327	610	31
CH1250	2,8	Copper Alloy	0,65	1250	1339	610	32
CH800	3,5	Copper Alloy	0,81	800	816	915	50
CH630	4,0	Copper Alloy	0,91	630	644	915	65
CH450	4,0	Copper Alloy	1,08	450	606	915	67
CH315	4,3	Copper Alloy	1,29	315	539	915	77
CH220	4,5	Copper Alloy	1,54	220	461	915	85
CH140	4,9	Copper Alloy	1,93	140	391	915	102
CH100	5,2	Copper Alloy	2,29	100	340	915	125
CC63	3,2	Copper	0,59	63	2189	915	41
CC40	3,4	Copper	0,74	40	2041	915	46
CC25	3,7	Copper	0,94	25	1655	915	56
CC17	4,6	Copper	1,14	17	516	915	85
CC11	4,9	Copper	1,41	11	460	915	98
CC7	5,3	Copper	1,77	7	391	915	118
CC4	5,9	Copper	2,34	4	315	915	150

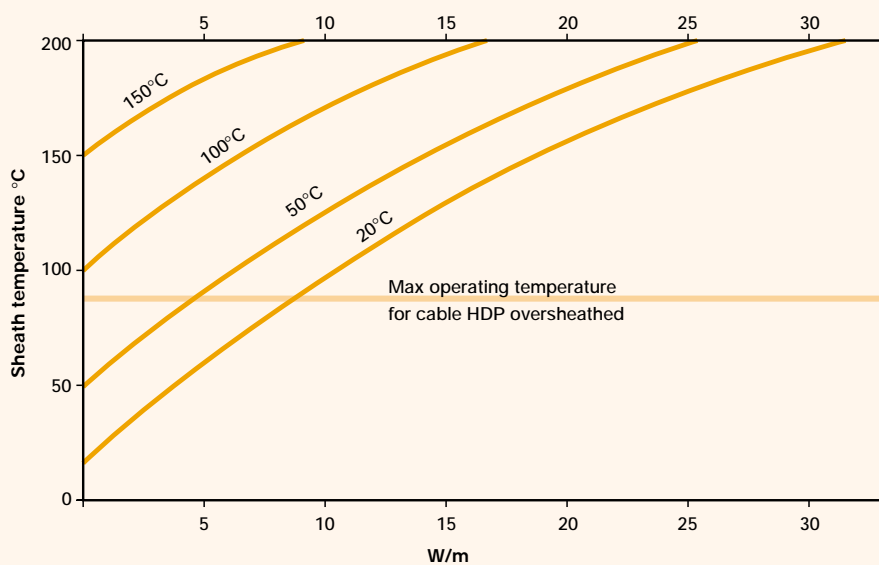

Correction factor table

Code	Bare	HDPE	FEP/PTFE
CH2000	1,076	0,714	-
CH1250	1,076	0,714	-
CH800	0,928	0,634	0,735
CH630	0,829	0,588	0,671
CH450	0,829	0,588	0,671
CH315	0,780	0,564	0,637
CH220	0,751	0,548	0,617
CH140	0,698	0,521	0,581
CH100	0,663	0,502	0,556
CC63	1,000	0,666	0,781
CC40	0,950	0,644	0,752
CC25	0,886	0,615	0,709
CC17	0,727	0,541	0,610
CC11	0,698	0,521	0,581
CC7	0,649	0,496	0,549
CC4	0,597	0,463	0,508

Sheath temperature

Max operating temperature for cable HDP oversheathed To calculate Maximum Operating Temperature, obtain watts per metre of cable, refer to ratings table, and multiply watts per metre by the ratio. Enter graph at "new" watts/metre, and read off sheath temperature at point of intersection of relevant maintain temperature.



MIC Cupro-nickel sheathed heating cables

Technical data

Code	Cable diameter (mm)	Conductor Material	Conductor Diameter (mm)	Resistance (Ω/Km)	Coil Length (m)	Spool Diameter (m)	Weight (Kg/Km)
DF1600	3,2	Ferry	0,62	1600	820	850	40
DF1000	3,4	Ferry	0,79	1000	742	850	45
DF630	3,7	Ferry	1,00	630	598	850	55
DF400	4,0	Ferry	1,25	400	530	850	67
DF250	4,4	Ferry	1,58	250	413	850	84
DF160	4,9	Ferry	1,97	160	333	850	108
DC63	3,2	Copper	0,59	63	813	850	39
DC40	3,4	Copper	0,74	40	724	850	44
DC25	3,7	Copper	0,94	25	591	850	55
DC17	4,6	Copper	1,14	17	393	850	84
DC11	4,9	Copper	1,41	11	329	850	98
DC7	5,3	Copper	1,77	7	292	850	119
DC4	5,9	Copper	2,34	4	232	850	155

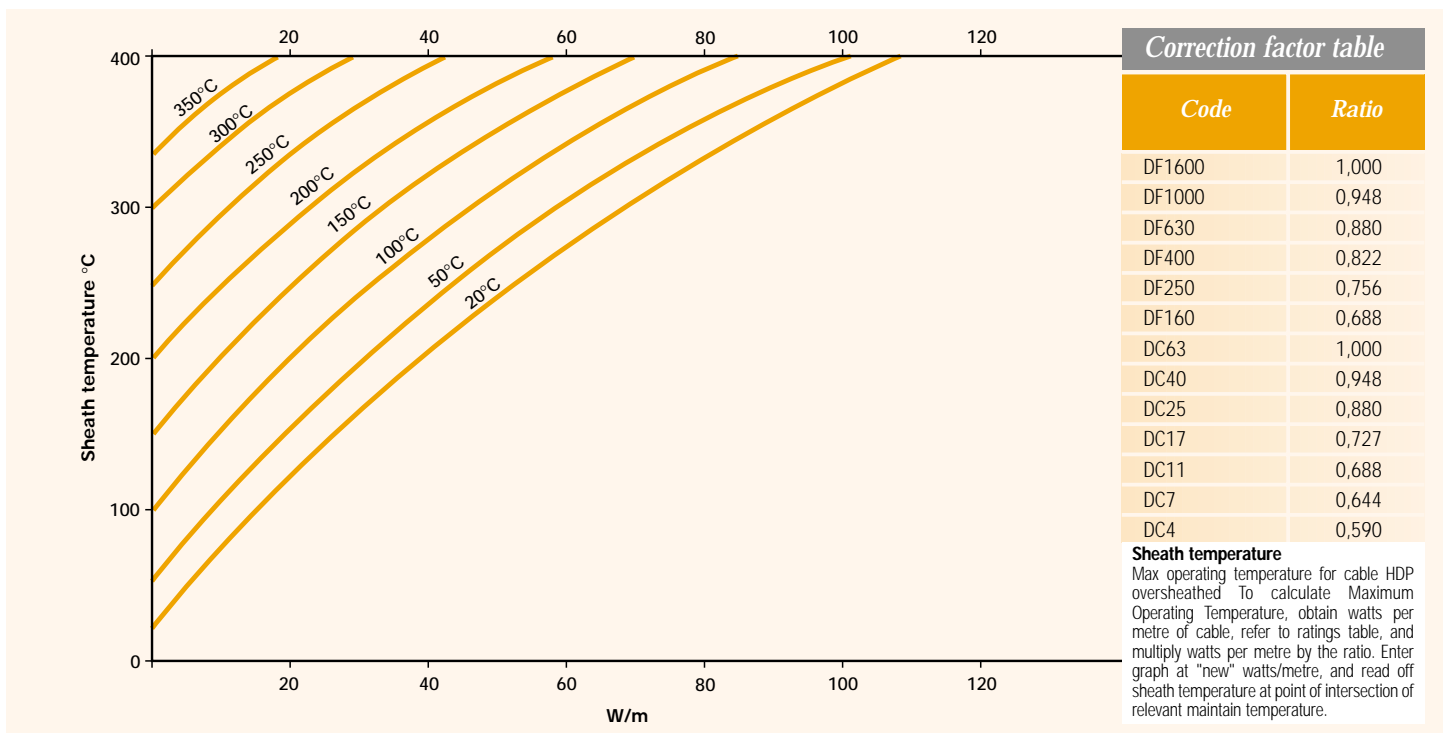



MIC Stainless steel sheathed heating cables

Technical data

Code	Cable diameter (mm)	Conductor Material	Conductor Diameter (mm)	Resistance (Ω/Km)	Coil Length (m)	Spool Diameter (m)	Weight (Kg/Km)
SQ10K	3,2	Nichrome	0,37	10000	268	610	39
SQ6300	3,2	Nichrome	0,47	6300	268	610	39
SQ4000	3,2	Nichrome	0,59	4000	268	610	39
SQ2500	3,4	Nichrome	0,74	2500	237	610	46
SQ1600	3,6	Nichrome	0,93	1600	205	610	52
SQ1000	3,9	Nichrome	1,17	1000	176	610	62
SQ630	4,3	Nichrome	1,48	630	140	610	78
SQ400	4,7	Nichrome	1,85	400	119	610	96
SQ250	5,3	Nichrome	2,35	250	94	610	127
SQ160	6,5	Nichrome	2,93	160	63	915	191

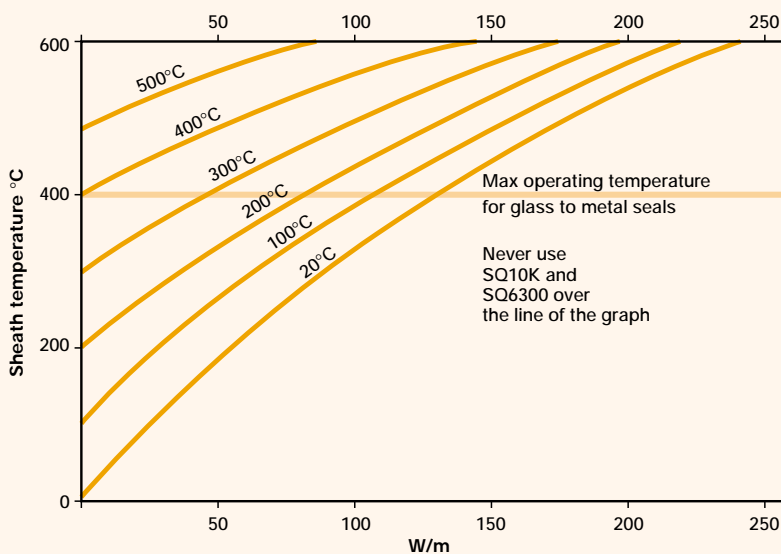

Correction factor table

Code	Correction factor
SQ10K	1,000
SQ6300	1,000
SQ4000	1,000
SQ2500	0,952
SQ1600	0,901
SQ1000	0,840
SQ630	0,769
SQ400	0,714
SQ250	0,645
SQ160	0,538

Sheath temperature

Max operating temperature for cable HDP oversheathed To calculate Maximum Operating Temperature, obtain watts per metre of cable, refer to ratings table, and multiply watts per metre by the ratio. Enter graph at "new" watts/metre, and read off sheath temperature at point of intersection of relevant maintain temperature.



MIC Types of standard heating elements

TYPE 1

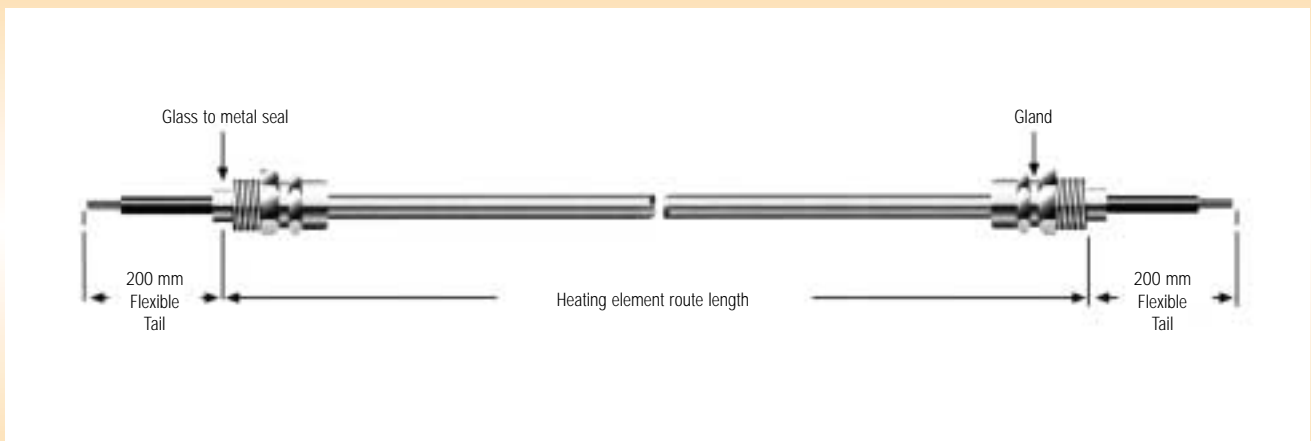

TYPE 2

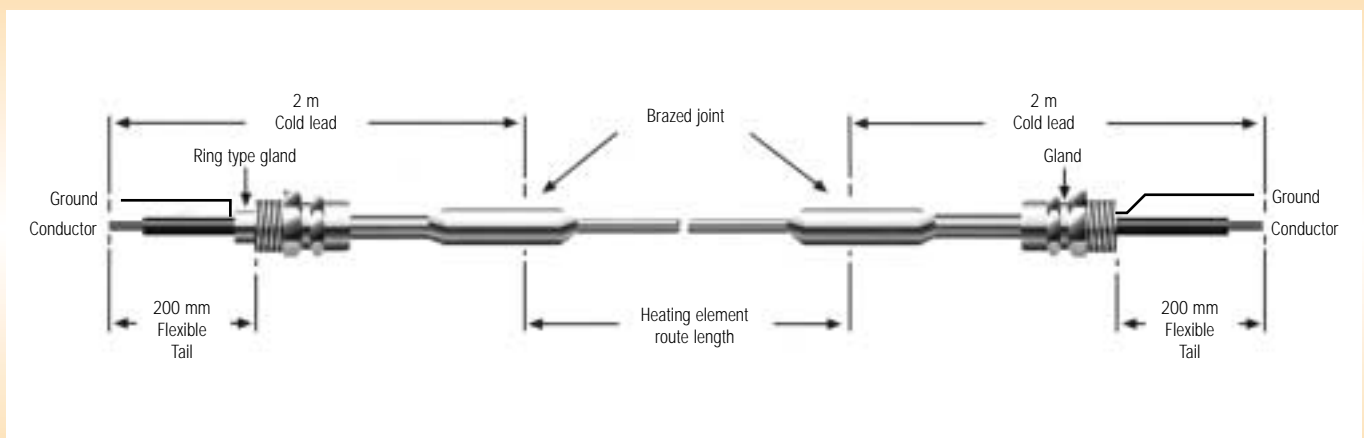

Installation procedures of self-regulating cables

A Straight installation

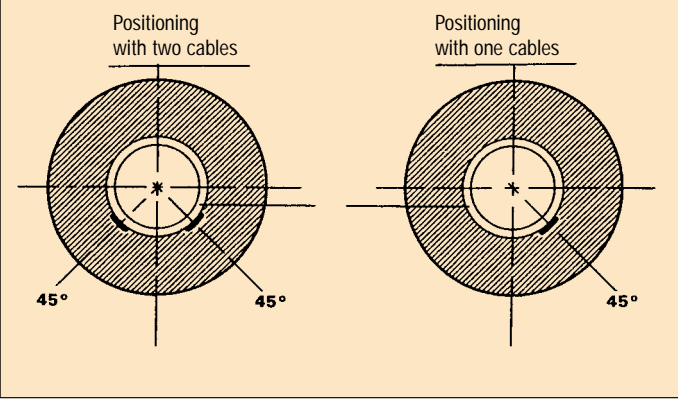

B Glass type fixing

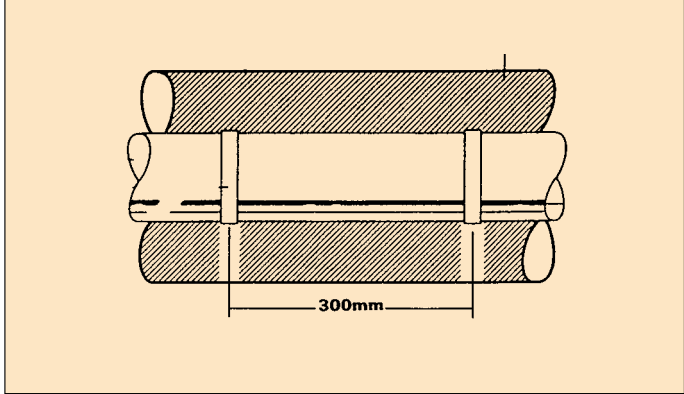

C Spiral installation

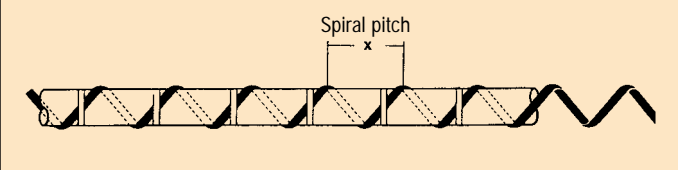

D Heat tracing of supports

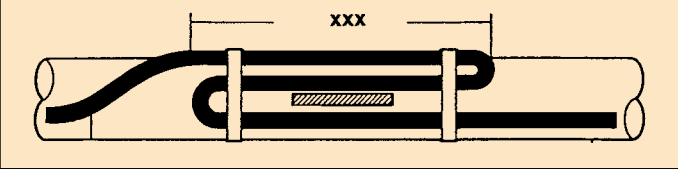

E Installation on a curve

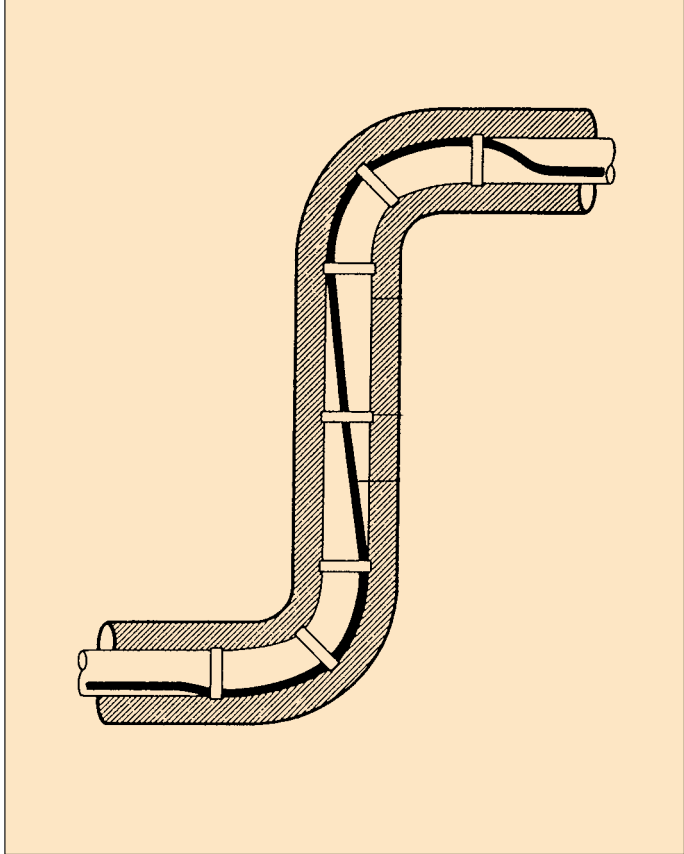

F Heat tracing of valves

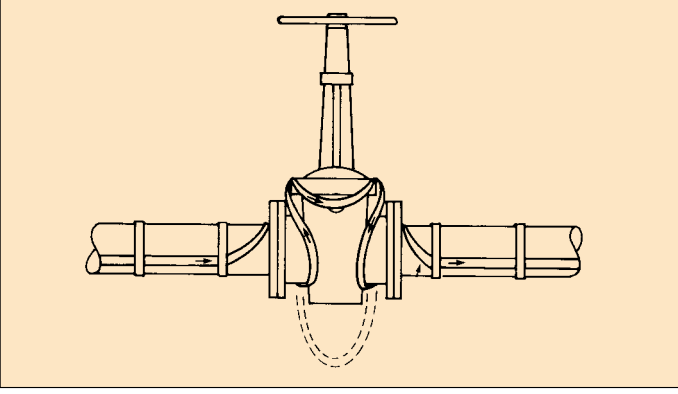

G Heat tracing of flanges

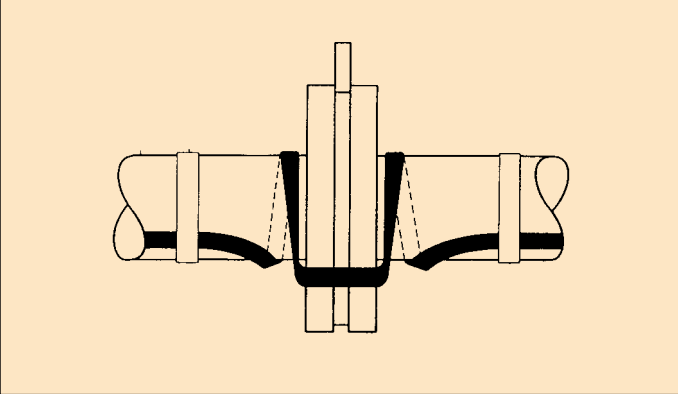

NOTE: other typicals on request

Installation procedures of MIC heating cables

A 3 traces installation

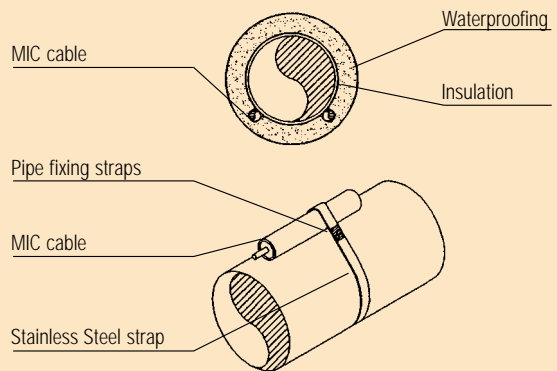

B 2 traces installation

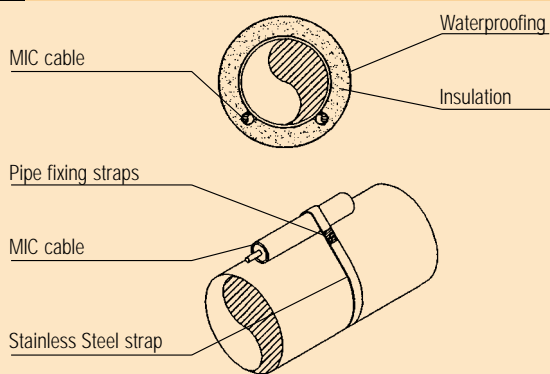

C Installation on straight pipe

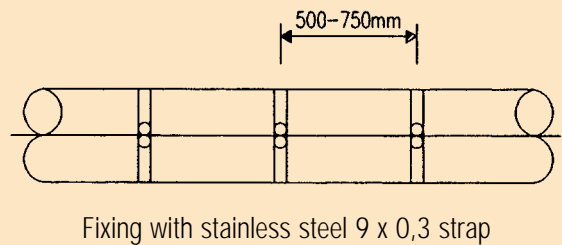

D Installation on tanks

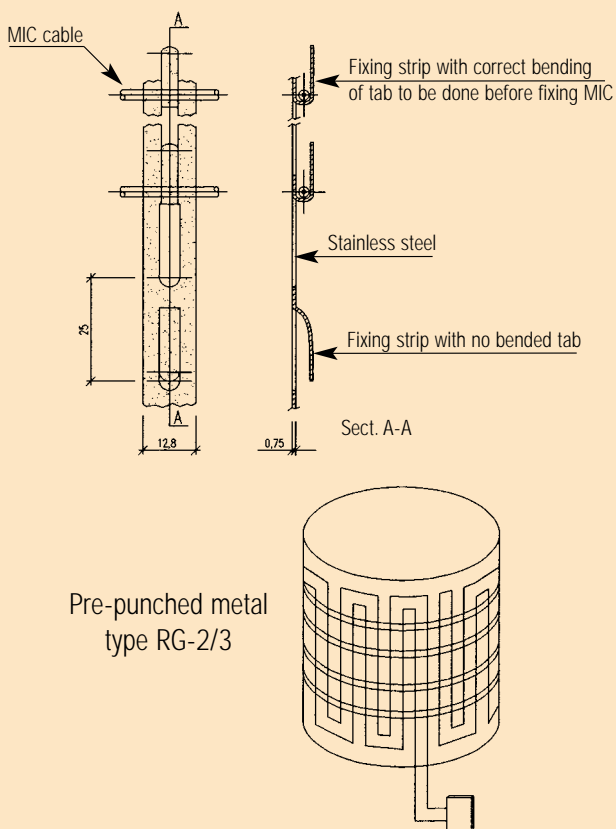

E Installation on flange

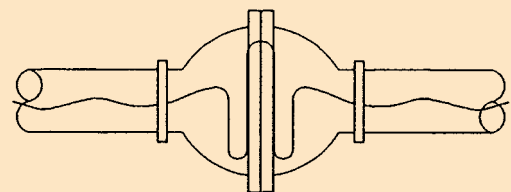

F Installation on curve

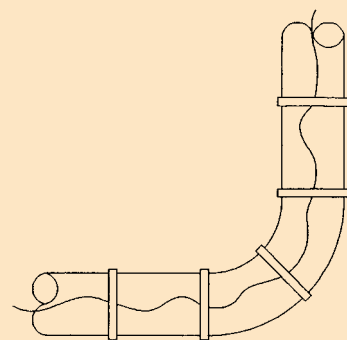

NOTE : Other typicals on request



Information table

heater power output (W/m) for temperature maintenance

Guide for oil and BTZ temperature maintenance
water recycling in heating systems. On request
calculations and design f.o.c.



Pipe Diameter	Maintenance a +5°C					Maintenance a +20°C					Maintenance a +40°C					Maintenance a +60°C				
	Insulation thickness (mm)					Insulation thickness (mm)					Insulation thickness (mm)					Insulation thickness (mm)				
	20	30	40	50	60	20	30	40	50	60	20	30	40	50	60	20	30	40	50	60
1/8"	2,4	2	1,8	1,6	1,5	5	4,1	3,7	3,4	3,1	8,6	7,1	6,3	5,8	5,4	12,5	10,3	9,1	8,4	7,8
1/4"	2,8	2,3	2	1,8	1,7	5,9	4,7	4,2	3,8	3,5	10,1	8,1	7,1	6,5	6	14,5	11,8	10,3	9,3	8,7
1/2"	3,7	2,9	2,5	2,2	2	7,5	6	5,1	4,6	4,2	13	10,2	8,8	7,9	7,3	18,7	14,8	12,7	11,4	10,5
3/4"	4,2	3,3	2,8	2,5	2,3	8,7	6,8	5,8	5,1	4,7	15	11,7	9,9	8,8	8,1	21,7	16,9	14,3	12,7	11,7
1"	4,9	3,8	3,2	2,8	2,5	10,1	7,8	6,5	5,8	5,2	17,4	13,4	11,2	9,9	9	25,1	19,3	16,2	14,3	13
1 1/2"	6,4	4,8	4	3,4	3,1	13,2	9,9	8,2	7,1	6,4	22,8	17	14	12,2	11	32,8	24,5	20,3	17,7	15,9
2"	7,6	5,6	4,6	4	3,5	15,7	11,6	9,4	8,2	7,3	27	19,9	16,2	14	12,5	39	28,7	23,4	20,3	18,1
2 1/2"	9,1	6,6	5,4	4,6	4,1	18,9	13,7	11,1	9,5	8,4	32,5	23,6	19,1	16,4	14,5	46,9	34,1	27,6	23,6	20,9
3"	10,4	7,5	6	5,1	4,5	21,5	15,5	12,4	10,6	9,3	36,9	26,6	21,4	18,2	16,1	53,3	38,5	30,9	26,3	23,2
4"	12,9	9,2	7,3	6,1	5,4	26,6	18,9	15	12,7	11,1	45,8	32,5	25,9	21,8	19,1	66,1	47	37,4	31,5	27,6
5"	15,5	10,9	8,6	7,2	6,3	32	22,5	17,8	14,9	13	55,1	38,8	30,6	25,7	22,3	79,5	56	44,2	37,1	32,2
6"	18,1	12,7	9,9	8,3	7,2	37,4	26,2	20,6	17,1	14,8	64,4	45	35,3	29,4	25,5	93	65	51	42,5	36,8
8"	23	16	12,4	10,3	8,8	47,6	33	25,6	21,2	18,3	81,9	56,7	44,1	36,5	31,4	118,2	81,9	63,7	52,7	45,4
10"	28,2	19,4	15	12,4	10,6	58,4	40,2	31,1	25,6	21,9	100,4	69,1	53,4	44	37,7	144,9	99,8	77,1	63,5	54,4
12"	33,2	22,7	17,5	14,4	12,3	68,5	46,9	36,1	29,7	25,3	117,9	80,8	62,2	51	43,6	170,2	116,6	89,8	73,7	62,9

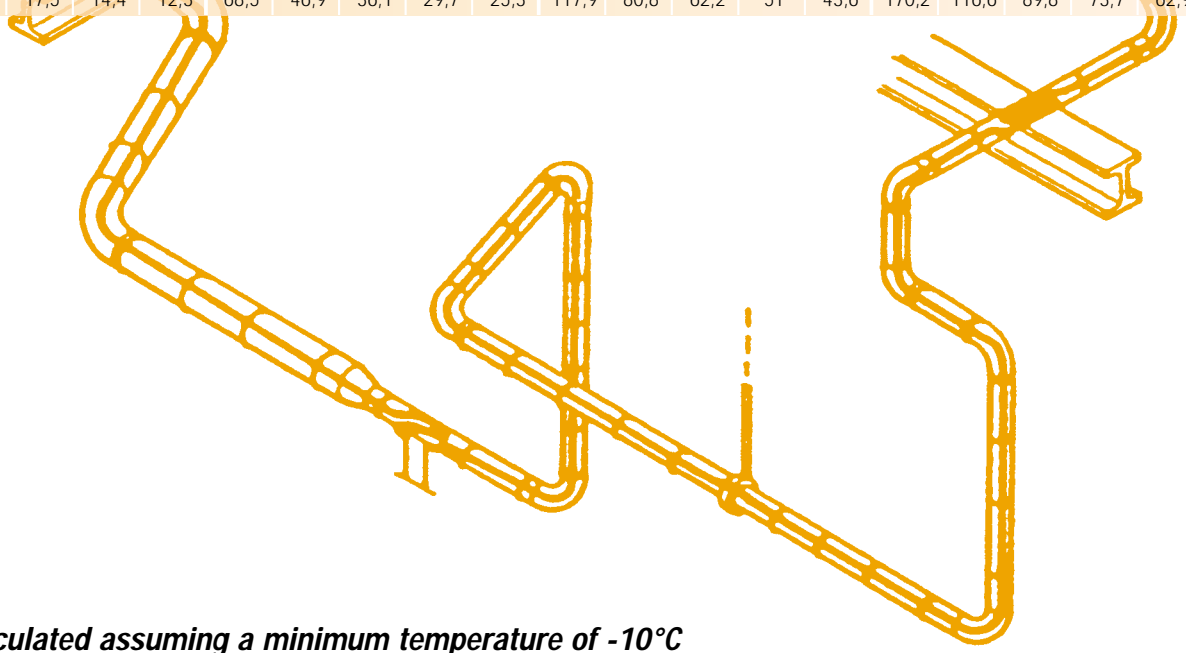

NOTE: values calculated assuming a minimum temperature of -10°C



Sigma Control srl

Via S. Maria Molgora, 60
20059 Vimercate (MI) Italy
Tel. 039 66.70.09
Fax 039 66.80.53
E-mail: info@sigmacontrol.it
www.sigmacontrol.it